



PROFESSIONAL SHOW LIGHTING

MINISCAN HPE

HTI 300

HMD 300

Congratulations on choosing a Clay Paky product! We thank you for your custom. Please note that this product, as all the others in the rich Clay Paky range, has been designed and made with total quality to ensure excellent performance and best meet your expectations and requirements.

INSTRUCTIONS MANUAL

Carefully read this instructions manual in its entirety and keep it safe for future reference.

It is essential to know the information and comply with the instructions given in this manual in order to ensure the fitting is installed, used and serviced correctly and safely.

CLAY PAKY S.p.A. disclaims all liability for damage to the fitting or to other property or persons deriving from installation, use and maintenance that have not been carried out in conformity with this instructions manual, which must always accompany the fitting.

CLAY PAKY S.p.A. reserves the right to modify the characteristics stated in this instructions manual at any time and without prior notice.

1 SAFETY INFORMATION

• Installation

Make sure all the parts for fixing the projector are in a good state of repair. Make sure the point of anchorage is stable before positioning the projector. The safety rope, properly hooked onto the fitting and secured to the framework, must be installed so that, if the primary support system fails, the fitting falls as little as possible. If the safety rope gets used, it needs to be replaced with a genuine spare.

• Minimum distance of illuminated objects

The projector needs to be positioned so that the objects hit by the beam of light are at least 1 metres (3'3") from the lens of the projector.

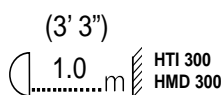

• Minimum distance of flammable materials

The projector must be positioned so that any flammable materials are at least 0.10 metres (4") from every point on the surface of the fitting.



It is permissible to mount the fitting on normally flammable surfaces.

• Maximum ambient temperature

For the fitting to operate well and reliably, the ambient temperature should not exceed 35°C (95°F).

• IP20 protection rating

The fitting is protected against penetration by solid bodies with a diameter of over 12mm (0.47") (first digit 2), but not against dripping water, rain, splashes or jets of water (second digit 0).

• Protection against electrical shock

This fitting is classified, in accordance with the type of protection against electrical shock, in **Class I**. It must therefore be connected to a power supply system with efficient earthing.

It is, moreover, recommended to protect the supply lines of the projectors from indirect contact and/or shorting to earth by using appropriately sized residual current devices.

• Hooking up to the supply mains

The operations for connecting to the electricity mains must be carried out by a qualified electrical installer.

Check that the mains frequency and voltage correspond to the frequency and voltage for which the projector is designed, given on the electrical data label.

This label also gives the input power. Refer to this to evaluate the maximum number of fittings to connect to the electricity line in order to avoid overloading.

• Maintenance

Before starting any maintenance work or cleaning the projector, cut off power from the supply mains.

After switching off, do not remove any parts of the fitting for 4 minutes. After this time the likelihood of the lamp exploding is virtually null. If it is necessary to replace the lamp, wait for another 15 minutes to avoid getting burnt.

The fitting is designed to hold in any splinters produced by a lamp exploding. The lenses must be mounted and, if visibly damaged, they have to be replaced with genuine spares.

• Temperature of the external surface

The maximum temperature that can be reached on the external surface of the fitting, in a thermally steady state, is 100°C (212°F).

• Lamp

 The fitting mounts a high-pressure lamp with an external igniter.

- Carefully read the "operating instructions" provided by the lamp manufacturer.
- Immediately replace the lamp if damaged or deformed by heat.



The products referred to in this manual conform to the European Community Directives to which they are subject:

- Low Voltage 73/23
- Electromagnetic Compatibility 89/336

2 INSTALLING THE PROJECTOR

• Unpacking

Open the cardboard box, take out the polystyrene wrapping and separate it, freeing the projector. Remove the plastic bag from the projector and position this on a horizontal top.

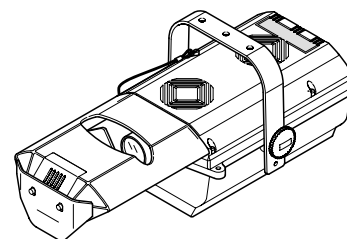

• Packing contents

Besides the projector, the packing also contains the following accessories:

- Safety rope code 105041/002 (1).
- Socket for mounting on cable code 030210 (2).
- This instructions manual code 099509 (3).
- Multilingual labels (4) with safety information code 081949/004 (located in the lamp compartment of the projector).

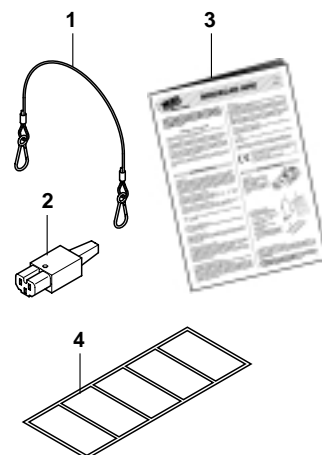

• Preparing the warning label

Find the relamping label (5) on the cover of the projector and, if necessary, replace it with one of the optional multilingual labels (4) in the lamp compartment of the projector. Read paragraph 5 MAINTENANCE for the instructions on opening the projector.

CAUTION: Read carefully and meticulously apply the information and instructions given on this label. In addition, check it is never removed as it contains important safety information.

• Projector mounting

Position the bracket (6) according to the desired angle and lock it with the knobs (7). The bracket (6) can be height adjusted by using the two holes on the bracket; it can moreover also be mounted towards the bottom of the fitting. To do this it is necessary to fully extract the knobs (7), reposition the bracket (6) in the desired position, put the knobs (7) back in and tighten them appropriately.

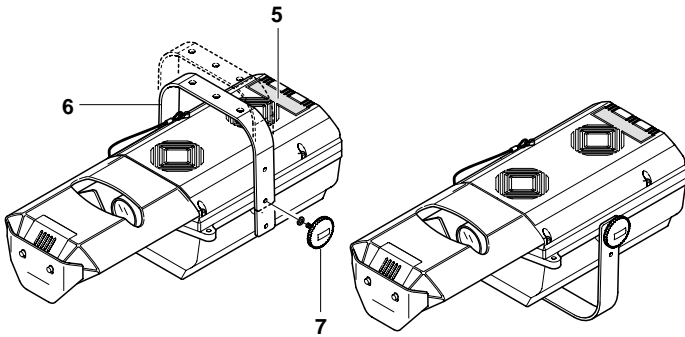

• Fitting the lamp

Refer to the instructions for opening the projector and changing the lamp in paragraph 5 MAINTENANCE.

• Installing the projector

The projector can be secured in any position without affecting its operating features.

Secure the projector in the desired position with the holes on the bracket (6) using two 10 mm screws \varnothing with nut and spring washer.

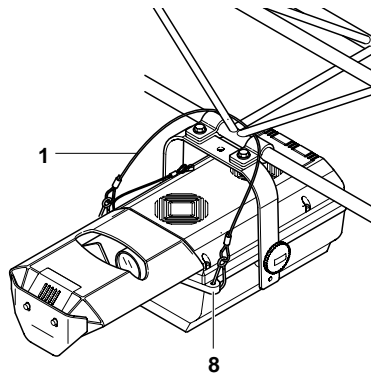

• Fixing the safety rope

It is compulsory to mount the safety rope (1). This has to be secured to the projector framework and then hooked onto the rings (8) on the base of the projector.

3 SUPPLY AND FINE-TUNING

• Mains power connection

The projector has to be hooked up to the electricity mains via the socket (2) supplied. It is advisable for each projector to be connected with its own switch so as to be able to switch it on and off individually from a distance.

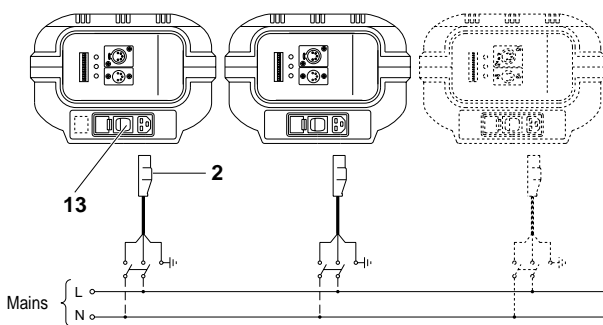

• Selecting the frequency 50/60Hz

Some MINISCAN HPE made to specific requirements are equipped with a device to quickly adapt the fitting to the frequency of the electricity mains. To select the right frequency, open the top cover, referring to the instructions in paragraph 5 MAINTENANCE and proceed as follows. Under the square of the mount of the terminal block (9), find the lever (10) of the frequency selector. With the aid of any tool that can be used on the lever (10), position it on the desired frequency, referring to the label (11).

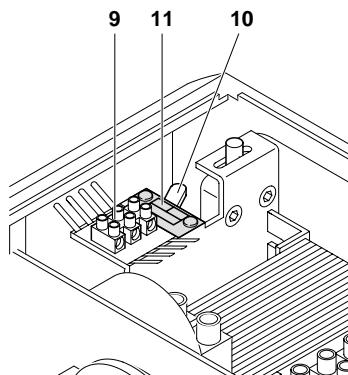

Connecting the control signals RS 232/423(PMX) - DMX 512

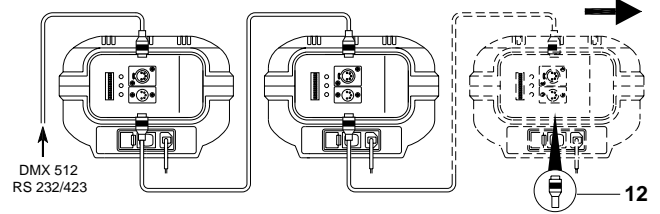

The connection between the projector and the control unit and between different projectors must be made with cable conforming to the EIA RS-485 specifications: braided, bipolar, shielded, 120 Ω of characteristic impedance, 22-24 AWG, low capacity.

IMPORTANT: Do not use a microphone cable or any other cable with different characteristics to the ones specified above.

The terminations need to be made with male/female connectors type XLR with 5 pins. If you use the DMX signal, on the last fitting it is necessary to add a terminal plug (12) with a resistance of 120 Ω (minimum 1/4 W) between the terminals 2 and 3.

If using the RS232/423(PMX) signal, the terminal is not required



IMPORTANT: The wires must make no contact with each other or with the metal casing of the connectors. The casing needs to be connected to the braid of the shield and to pin 1 of the connectors.

• Switching on the projector

After carrying out all the above operations, press the switch (13) checking that the lamp comes on and the automatic resetting sequence starts.

• Projector coding

Every MINISCAN HPE occupies 7 control channels. For these to be correctly addressed to each projector it is necessary to code the projectors.

This has to be done on each single MINISCAN HPE, switching the microswitches (14) according to the following table. The coding can also be done with the projector switched off.

Spotlight selection

OPTION SELECT AND START ADDRESS

▲ TILT ▼

▲ PAN ▼

TEST

256

128

64

32

16

8

4

2

1

ON ←

STATUS LEDS

DATA ERROR

PMX

DMX

DIGITAL INPUT

PIN CONNECTIONS

PMX

RS232/423

1=SCREEN \updownarrow

2=SIGNA \updownarrow

3=SIGNA \updownarrow

DMX 512

1=SCREEN \updownarrow

2=SIGNA \updownarrow

3=SIGNA \updownarrow

CHANNEL ASSIGNMENTS

1 = ROTATING COLOURS

2 = GOTO ROTATION

3 = GOTO CHANGE

4 = DIMMER/STROBE

5 = PAN

6 = TILT

7 = COLOR & EFFECTS

THE DIGITAL START ADDRESS IS THE SUM OF THE NUMBERS PRODUCED BY THE SELECTED SWITCHES

		CODE							1	2	4	8	16	32	64	128	TEST
Projector 1	- Channels 1-7	ON	▲	▼	▼	▼	▼	▼	▼	▼	▼	▼	▼	▼	▼	▼	▼
Projector 2	- Channels 8-14	ON	▼	▼	▼	▲	▼	▼	▼	▼	▼	▼	▼	▼	▼	▼	▼
Projector 3	- Channels 15-21	ON	▲	▲	▲	▲	▼	▼	▼	▼	▼	▼	▼	▼	▼	▼	▼
Projector 4	- Channels 22-28	ON	▼	▲	▲	▲	▲	▼	▼	▼	▼	▼	▼	▼	▼	▼	▼
Projector 5	- Channels 29-35	ON	▲	▼	▲	▲	▲	▲	▼	▼	▼	▼	▼	▼	▼	▼	▼
Projector 6	- Channels 36-42	ON	▼	▼	▲	▲	▲	▲	▲	▼	▼	▼	▼	▼	▼	▼	▼
Projector 7	- Channels 43-49	ON	▲	▲	▼	▲	▲	▲	▲	▲	▼	▼	▼	▼	▼	▼	▼
Projector 8	- Channels 50-56	ON	▼	▲	▼	▼	▲	▲	▲	▲	▲	▼	▼	▼	▼	▼	▼
Projector 9	- Channels 57-63	ON	▲	▲	▲	▲	▲	▲	▲	▲	▲	▼	▼	▼	▼	▼	▼
Projector 10	- Channels 64-70	ON	▼	▼	▼	▼	▼	▼	▼	▼	▼	▼	▼	▼	▼	▼	▼
		ON	▼	▼	▼	▼	▼	▼	▼	▼	▼	▼	▼	▼	▼	▼	▼
		OFF	▼	▼	▼	▼	▼	▼	▼	▼	▼	▼	▼	▼	▼	▼	▼

On turning the TEST microswitch (15) onto the ON position, the projector runs a self-check routine, during which the effects are mechanically reset, with the projector on. At the end of the operation, or whenever you want to interrupt this procedure, turn the TEST microswitch back onto OFF.

Whereas, on setting all the channels on level 0 (blackout), after an interval of 2 seconds, the effects are re-calibrated, thanks to which it is possible, from the control unit, to take back onto the correct position any motorized effects that during operation had accidentally "lost step".

The entire re-calibration cycle lasts approximately 35 seconds and can be stopped at any time by simply setting a channel at a level above 0.

4 PROJECTOR POSITIONING

Before proceeding, set the channels as shown in the following table.

CHANNEL	CURSOR POSITION
1 COLOUR DISC	0 % (white spot)
2 GOBO ROTATION	-
3 GOBO SELECTION	-
4 DIMMER / STOP / STROBE	100 % (white spot)
5 PAN	50 % (central position)
6 TILT	50 % (central position)
7 EFFECTS DISC	0 % (white spot)

• Light beam centring

After carrying out the operations described, loosen the knobs (7), proceed by moving the projector on the bracket (6) to position the beam of light on the central point of the scene, then lock the knobs (7).

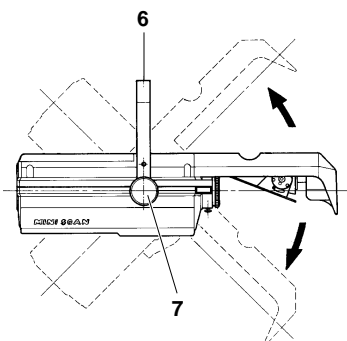

• Adjusting the lens

Move the lens (16) axially to obtain perfect focusing of the projected image, then lock the handwheel (17).

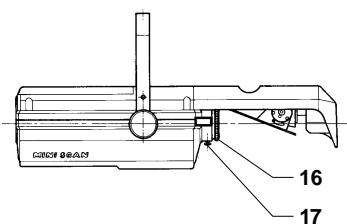

• Adjusting the lens hood

Loosen the two handwheels (18), move the lens hood (19) in the directions shown by the arrows and lock it in the desired position by tightening the two handwheels (18).

Check the positioning of the lens hood by taking the TILT to 100% (with microswitch 12 in the OFF position) and moving the PAN from 0% to 100%.

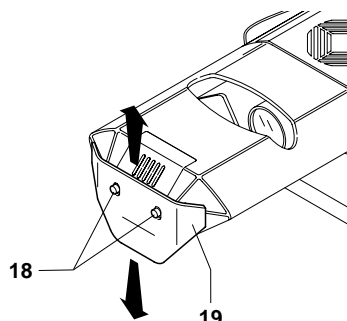

5 MAINTENANCE

• Opening and closing the projector

Loosen the handwheel (20) and slightly lift the top cover (21), then forcing it sideways in the direction shown by the arrow free the cover from the body of the projector.

After maintenance, fit the top cover (21) back on, repeating the previous sequence in reverse order.

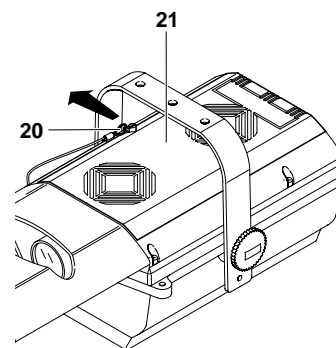

• Re-lamping

After opening the projector, loosen the two side ring nuts (22) of the lamp to replace and remove it from the mountings (23).

Take the new lamp out of its package, loosen the two side ring nuts (22) and insert it in the mountings (23). Finally, screw on the ring nuts.

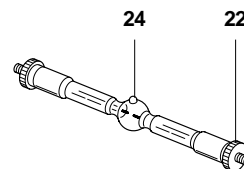
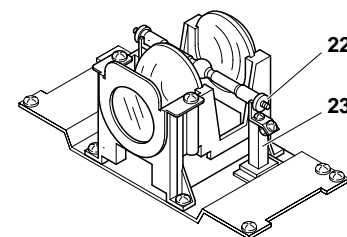

IMPORTANT: To distribute the beam of light uniformly, the lamp needs to be positioned with the protrusion (24), visible on the bulb, outside the optical axis of the projector. For this purpose it is recommended to turn the protrusion towards the top cover of the projector

• Replacing fuses

To replace the fuses, press the tab (25) and take out the fuse-holder box (26). Replace blown fuses with new ones of the type specified on the label (27) on the fuse-holder box (26). Put it back in so the tab (25) clicks home.

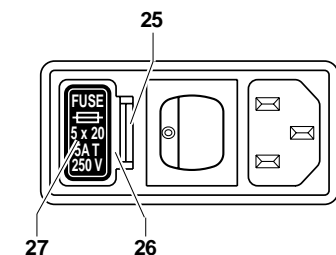

• Removing the lens hood plate

Before carrying out the routine maintenance operations on the effects unit, described below, it is necessary to remove the lens hood plate (28) by unscrewing the two handwheels (29), take care not to drop them inside the projector.

After the necessary maintenance, fit the lens hood plate (28) back on, securing it with the two handwheels (29).

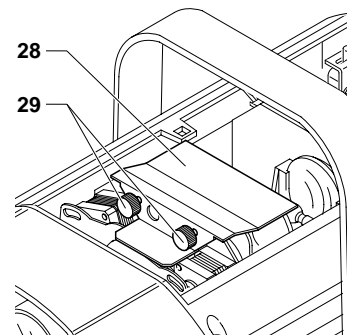

• Periodical cleaning

To keep optimum efficiency and functionality over time, it is vital to periodically clean the parts where dust and grease can accumulate.

The frequency with which to carry out the following operations depends on several factors, such as the number of movements of the effects and the quality of the work environment (air humidity, dust, saltiness, etc.).

To remove dirt from the lenses and filters, use a soft cloth dampened with any liquid detergent for cleaning glass.

Never use solvents or spirits.

- Parts requiring frequent cleaning.
- Parts requiring monthly cleaning.

Once a year it is recommended to submit the projector to qualified technical personnel for non-routine maintenance consisting of at least the following operations:

- General cleaning of internal parts.
- Restoring lubrication of all parts subject to friction, using lubricants specifically supplied by Clay Paky.
- General inspection of internal components, wiring, mechanical parts, etc.
- Electrical, photometric and functional tests.
- Any repairs.

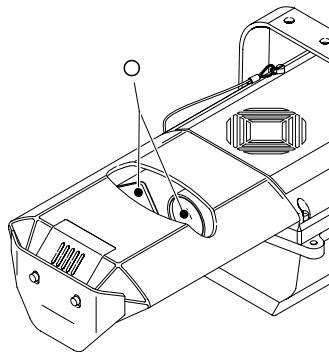
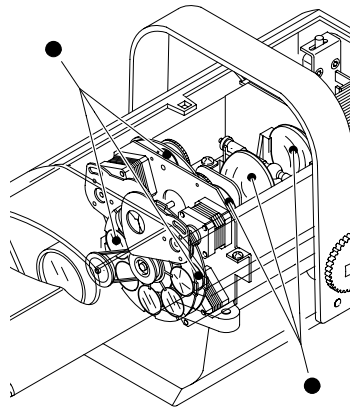

6 TROUBLESHOOTING

THE PROJECTOR WILL NOT SWITCH ON			TROUBLE
THE ELECTRONICS DO NOT WORK			
DEFECTIVE PROJECTION			
REDUCED BRIGHTNESS			
	POSSIBLE CAUSES	CHECKS AND REMEDIES	
●	No mains supply.	Check the supply socket is powered and/or fuse conductivity.	
●	Lamp exhausted or defective.	Replace the lamp (see instructions).	●
●	Signal transmission cable short-circuited or disconnected.	Replace cables.	●
●	Wrong coding.	Check coding (see instructions)	●
●	Defect in electronic circuits.	Call an authorized technician.	●
●	Lens broken.	Call an authorized technician.	●
●	Dust or grease deposited.	Clean (see instructions).	●

7 TECHNICAL DATA

Power supplies available

- 220-240V 50Hz
- 200V 50Hz - 230V 60Hz
- 200-220V 60Hz
- 260V 50Hz
- 120V 60Hz
- 100V 50Hz
- 100V 60Hz

The projector is designed to work at the frequency and voltage given on the electrical data label on the back of the appliance.

Lamp

Metal halide supplied with special built-in power supply unit.

- Type HTI 300W
 - Connection SFC 10-4
 - Colour temperature 6,500 K
 - Luminous flux 22,000 lm
 - Average life 750 h
 - Any working position
- Type HMD 300W
 - Connection SFC 10-4
 - Colour temperature 5,700 K
 - Luminous flux 20,000 lm
 - Average life 3,000 h
 - Working position p45

Input power

- 900VA at 230V 50Hz

Motors

8 stepper motors, operating with micro-steps, totally microprocessor controlled..

Optical unit

- Base in die-cast aluminium.
- Twin lens condenser.
- Spherical reflector with a high luminous efficiency.

Lens units

- Standard: 1:1,6/100 mm (16,6°)
- Optional: 1:2,8/120 mm (13,6°)
- Optional: 1:2,2/135 mm (12,6°)

Channels

N. 7 control channels.

Inputs

- RS232/423(PMX)
- DMX 512

Moving mirror

- Mirror with extra high luminous efficiency
- Movement by means of two stepper motors, controlled by microprocessor.

Travel:

- PAN = 150°
- TILT = 110°

Maximum speeds:

- PAN = 0.4 sec (150°)
- TILT = 0.3 sec (110°)

Resolution:

- PAN = ± 0.3°
- TILT = ± 0.2°

Safety Devices

- Automatic break in power supply in case of overheating or failed operation of cooling system.
- Power supply automatically cut off on opening the cover.
- Two safety rope fixing points.

Cooling

Forced ventilation with axial fans.

Body

In die-cast aluminium painted with epoxy powders.

Mounting

- In steel painted with epoxy powders.
- Two installation positions with a step of 50 mm (1,97").
- Adjustable on 110°.
- Safety rope fixing point.

Working position

Operation in any position, limited to the specifications of the lamp used.

Weights and dimensions

Versions 200-240V: 13 kg (28 lbs 10 ozs)
 Versions 100-120V: 16 kg (35 lbs 3 ozs)

